

DELER - SPARES

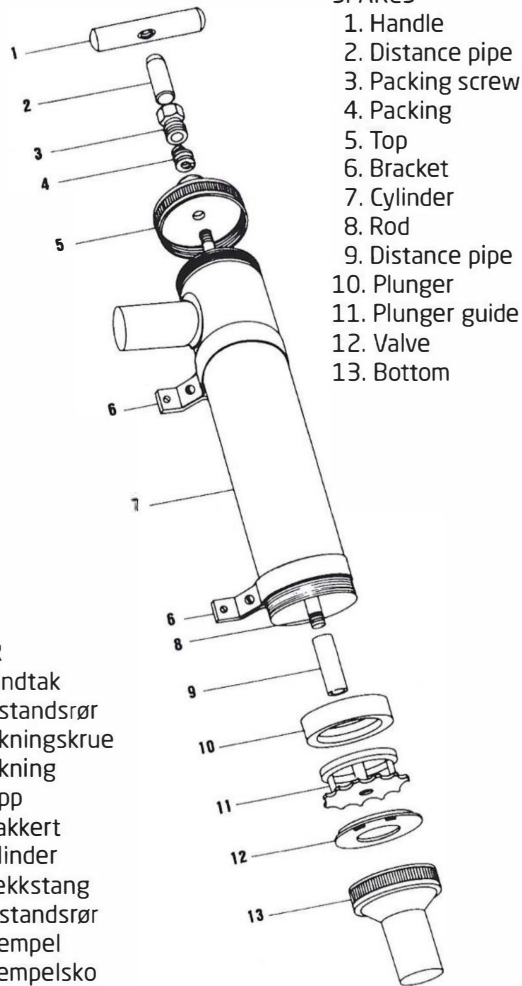

- SPARES
1. Handle
 2. Distance pipe
 3. Packing screw
 4. Packing
 5. Top
 6. Bracket
 7. Cylinder
 8. Rod
 9. Distance pipe
 10. Plunger
 11. Plunger guide
 12. Valve
 13. Bottom

- DELER
1. Håndtak
 2. Avstandsør
 3. Pakningskrue
 4. Pakning
 5. Topp
 6. Brakkert
 7. Sylinder
 8. Trekkstang
 9. Avstandsør
 10. Stempel
 11. Stempelsko
 12. Bunnventil
 13. Bunn

I enhver båt bør det monteres en HÅND LENSEPUMPE. Denne brosjyre viser Norske kvalitetspumper passende til både bruks- og lystbåter, produsert av de beste materialer som kan skaffes. Sylinderpumpene har varmpresset topp og bunn som garanterer et absolutt tett gods, sylinder i heltrukne messingrør, stempel og ventil i oljebestandig synt. gummi. Alle pumper er enkel å demontere - nødvendige reservedeler leveres.

Hvor sikkerhet og effekt forlanges brukes «SKULSTAD» pumper.

Every boat should have a hand bilge pump monted. In this brochure we demonstrate Norwegian quality pumps suitable for both comercial and pleasure boats, produced of the very best material available. The cylinder form a seamless brass tubing with molded top and bottom, which guarantees a water resistant pump. To ensur longer life, the Skulstad Pumps have Nitrile rubber in the plunger and valves.

Where PERFORMANCE counts use «SKULSTAD» pumps.



MJÅTVEITFLATEN 39C - 5918 FREKHAUG
 TLF: 482 36 844
 www.fremas.no
 e-post: firmapost@fremas.no

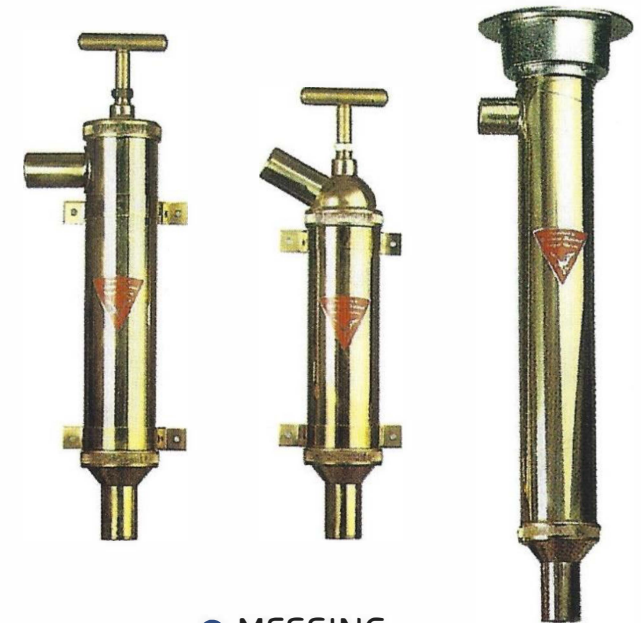

- MESSING
- SELVSUGENDE
- ROBUSTE
- KVALITET



- SELF PRIMING
- QUALITY

SKOTTPUMPER BULKHEAD PUMPS



		Nr. 1	Nr. 1A	Nr. 2	Nr. 2A	Nr. 2B
Total lengde	Overall length	58 cm	40 cm	55 cm	45 cm	31 cm
Sylinder dia.	Cylinder diam.	63 mm	63 mm	63 mm	63 mm	35 mm
Inn og uttak.	Hose size	32 mm	32 mm	32 mm	32 mm	19 mm
Kapasitet ltr.	Capacity pr. 60 slag	60	30	55	40	9
Finish		POLERT	POLERT	POLERT	POLISHED	POLISHED

DEKKSPUMPE DECK FITTING PUMP

UTTAKSRØR Nr. 3A

Total lengde	80 mm
Rørdiam.	32 mm
Flensdiam.	60 mm
Finish	Krom

PUMPE Nr. 3

Total lengde	51 cm
Sylinder	63 mm
Inn og uttak	32 mm
Flens diam.	130 mm
Kapasitet	50 ltr.
pr. 60 slag	



OUTLETPPIPE No 3A

Overall length	80 mm
Pipe diameter	32 mm
Flange diameter	60 mm
Finish	Chromium plated

PUMP No 3

Overall length	51 cm
Cylinder diameter	63 mm
Hose size	32 mm
Flange diameter	130 mm
Capacity	50 ltr.

En smart pumpe for montering i dekk, enkel å montere. Fell den ned i dekk - monter en slange mellom pumpens og båtsidens uttakrør - vi anbefaler å bruke Nr 3A med dryppkant.

Den hendige BAJONETTLÅSEN sikrer lokket. Med et enkelt håndgrep åpnes og lukkes lokk for bruk.

This pump can easily be installed at the boat deck. The enclosed top avoids any spill on deck. Mount the pump into the deck, and insert a hose between the pump and the retrieval tube at the side of the boat. We recommend using No 3A with drip edge.

A handy bayonet lock secures the lid. Easy to open and close - simply turn the cover.

FREKHAUG MASKINERING AS

PAKNINGSSETT

Pumpe 1 - 1A - 2 - 2A - 3



Pumpe 2 B



GEIDESPRØYTER



	Nr. 8-40	Nr. 8-35	Nr. 8-30
Total lengde	55 cm	50 cm	45 cm
Sylinder dia.	35 mm	35 mm	35 mm
Finish	POLERT	POLERT	POLERT

TA KONTAKT MED OSS

OIL DRAINING PUMPS